

STEAMPAC™ WT BOILERS



With over 40 years of experience, Windsor Energy is a world class supplier of energy systems to a diverse range of industries and institutions. Windsor is renowned for delivering efficient and reliable thermal energy systems and continues to improve its product range with the latest technological developments. The revolutionary Steampac™ Water Tube (WT) boiler range integrates the best design features of gas/oil-fired package boilers.

Steampac™ WT

The Windsor Energy Steampac™ WT boilers are an industry standard water-tube D-type boiler configuration. Capacities range from 2MW to 30MW rated output. These boilers are designed in house and manufactured in accordance with Australian and New Zealand Standards, AS 1228 and AS 2593.

Key Features

- Membrane wall sealed furnace construction
- In-drum steam separation for dry steam output
- Heavy duty economiser (standard from 6MW) for the highest possible efficiencies
- Windsor's own E-boiler PLC based control system
- Digital combustion management system
- Fitted with high performing Weishaupt or Dreizler burners as standard
- Standard pressures up to 17.5 bar, higher pressures possible on request
- Access to both ends of the steam drum
- Unattended status - all models are fully compliant with AS2593 and New Zealand requirements for unattended operation

Larger sizes and higher pressures/temperatures are covered in the licensed Babcock & Wilcox product range, further information is available on request.

Five reasons to invest in Steampac™ WT

- Designed in New Zealand
- Safe, efficient, and durable water tube boiler plant comprehensively engineered and fully guaranteed
- Fast reaction time and high ramp rate effortlessly handles variations in steam load
- Wide range of firing fuels (gas, light and heavy fuel oils) with dual fuel options
- Full after-sales support from Windsor Energy's nationwide service division in New Zealand

Accessories and Options

- Reduced NOx (or Low NOx) burner
- Integrated oxygen trim
- Variable speed fan
- Automatic continuous blowdown system for longer boiler life
- Feedwater tank
- Blowdown receiver
- Stack
- Access ladder and gallery
- Complete boiler system installation, commissioning and training on site
- Specialist, technical service for maintenance, annual surveys and energy system expertise throughout New Zealand

STEAMPAC™ WT BOILERS

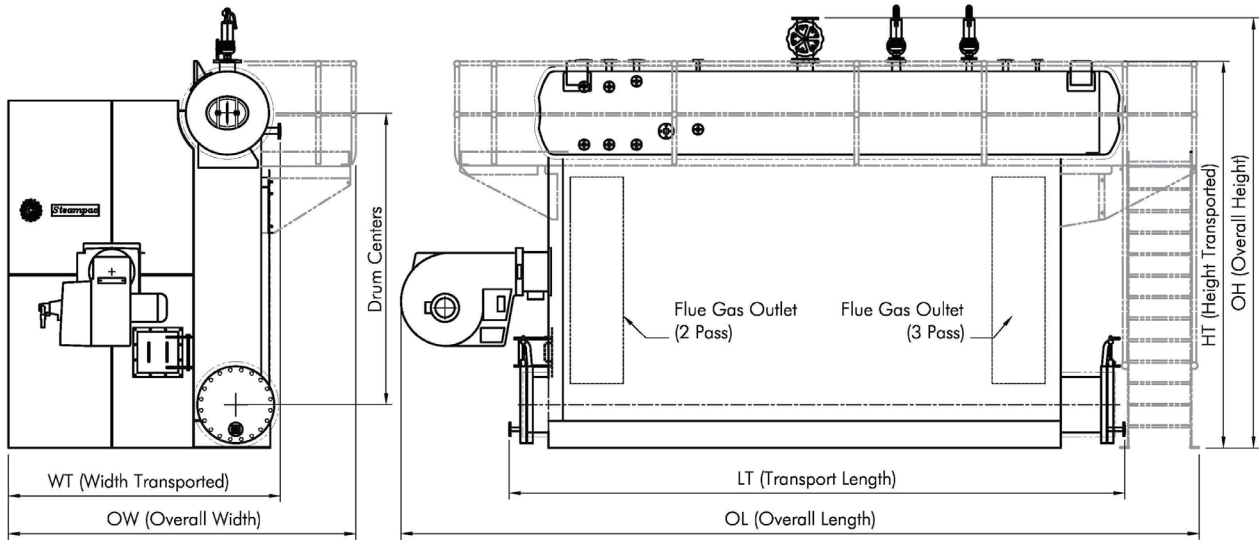

STEAMPAC MODEL	2	3	4	5	6	8	10	12.5	15	17.5	20
THERMAL OUTPUT kW	2000	3000	4000	5000	6000	8000	10000	12500	15000	17500	20000
STEAM RATING* kg/h	3190	4785	6380	7975	9570	12760	15950	19938	23926	27913	31901
DRY WEIGHT kg	9500	9500	10000	10500	12000	14000	16000	18000	21000	24000	27000
FLOODED WEIGHT kg	11800	11850	12401	13720	15621	18473	20266	23884	26904	30072	33120
OVERALL HEIGHT (OH) mm	3850	3850	4080	4080	4080	4300	4300	4500	4630	4830	4830
OVERALL WIDTH (OW) mm	3300	3300	3550	3750	3850	3750	3750	4050	4100	4200	4300
OVERALL LENGTH (OL) mm	5800	6100	6800	7350	7800	8450	9200	9600	10200	10700	11400
TRANSPORT HEIGHT (HT) mm	3500	3500	3600	3600	3600	3700	3700	3900	3900	4100	4100
TRANSPORT WIDTH (WT) mm	2400	2400	2650	2850	2950	2850	2850	3150	3200	3300	3400
TRANSPORT LENGTH (LT) mm	4900	5200	5900	6450	6900	7550	8100	8700	9300	9800	10500
No of PASSES	3	3	3	3	3	2	2	2	2	2	2
STEAM DRUM INSIDE DIA mm	575	575	762	762	762	914	914	914	914	914	914
DRUM CENTRE - CENTER mm	2250	2250	2250	2250	2250	2250	2250	2750	2750	2950	2950
STACK DIA mm	400	480	550	610	660	750	830	920	1000	1070	1150
BOILER BACK PRESSURE mbar	5.4	8.4	G60/2-A	G70/2-A	G70/2-A	G70/2-A	WKG70/2-A	WKG80	WKG80	WKG80	WKG80
FAN kW (INT = INTEGRAL or EXT = EXTERNAL)	5.5 (INT)	9 (INT)	13.5 (INT)	21 (INT)	21 (INT)	21 (INT)	35 (EXT)	35 (EXT)	35 (EXT)	TBA (EXT)	TBA (EXT)
WATER FEED NB	40	40	40	50	50	50	50	65	65	80	80
MAIN STOP NB	100	100	150	150	150	200	200	200	250	250	250
SAFETY VALVES NB 10 bar	25	32	32	40	40	50	50	65	65	80	80
SAFETY VALVES NB 17 bar	20	25	25	32	32	40	40	50	50	65	65
NATURAL GAS Nm ³ /h	200	300	400	500	600	750	930	1160	1400	1630	1860
GAS MAIN SIZE NB	40	65	65	80	80	100	125	150	TBA	TBA	TBA
ECONOMISER	OPTIONAL	OPTIONAL	OPTIONAL	OPTIONAL	OPTIONAL	STANDARD	STANDARD	STANDARD	STANDARD	STANDARD	STANDARD
ECONOMISER HEIGHT	-	-	-	-	-	1954	1954	2004	2150	2150	2154
ECONOMISER WIDTH	-	-	-	-	-	846	1050	1021	1148	1402	1652

Due to our policy of continuous improvement, dimensions and other details may change without notice.

Thermal efficiency and full performance data for each model will be provided on request.

*Steam rating is evaporation rate from & at 100°C

Why Windsor Energy?

As a trusted provider of energy plant and services in New Zealand and around the world, Windsor Energy offers the following advantages:

- Extensive installed base of heat plants in a range of industries.
- Modular plant package, optimised for long-distance transport of components, and efficient, safe assembly at destination.
- Innovative plant design for high efficiency, simple operation, high availability and low overall cost of ownership.

Contact Us

Level 2
6 Albion Street, Napier
4110
PO Box 1045, Napier 4140
New Zealand
P +64 6 899 5050
E energy@windsor.co.nz
www.windsorenergy.co.nz